

LMV232

Dual-Channel Integrated Mean Square Power Detector for CDMA & WCDMA

General Description

The LMV232 dual RF detector is designed for RF transmit power measurement in mobile phones. This dual mean square IC is especially suited for accurate power measurement of RF signals exhibiting high peak-to-average ratios used in 3G and UMTS/CDMA applications. The LMV232 saves calibration steps and system certification and is highly accurate. The circuit operates with a single supply from 2.5 to 3.3V.

The LMV232 contains a mean square detector with two sequentially selectable RF inputs. The RF input power range of the device has been optimized for use with a 20 dB directional coupler, without the need for additional external components. A single external RC combination between FB and OUT provides an externally configurable gain and LF filter bandwidth of the device.

The device has two digital interfaces. A shutdown function is available to set the device in a low-power shutdown mode. In case SD = HIGH, the device is in shutdown, if SD = LOW the device is active. The Band-Select function controls the selection of the active RF input channel. In case BS = HIGH, RF_{IN1} is active. In case BS = LOW, RF_{IN2} is active.

The dual mean square detector is offered in an 8-bump micro SMD 1.5 x 1.5 x 0.6 mm package. This micro SMD package has the smallest footprint and height.

Features

- >20 dB square-law detection range
- 2 sequentially selectable RF inputs
- Low power consumption shutdown mode
- Externally configurable gain and LF filter bandwidth.
- Internal 50Ω RF termination impedance
- Optimized for use with 20 dB directional coupler
- Lead free 8-bump micro SMD package 1.5 x 1.5 x 0.6 mm

Applications

- 3G mobile communications
- UMTS
- WCDMA
- CDMA2000
- TD-SCDMA
- RF control
- Wireless LAN
- PC Card and GPS modules

Typical Application

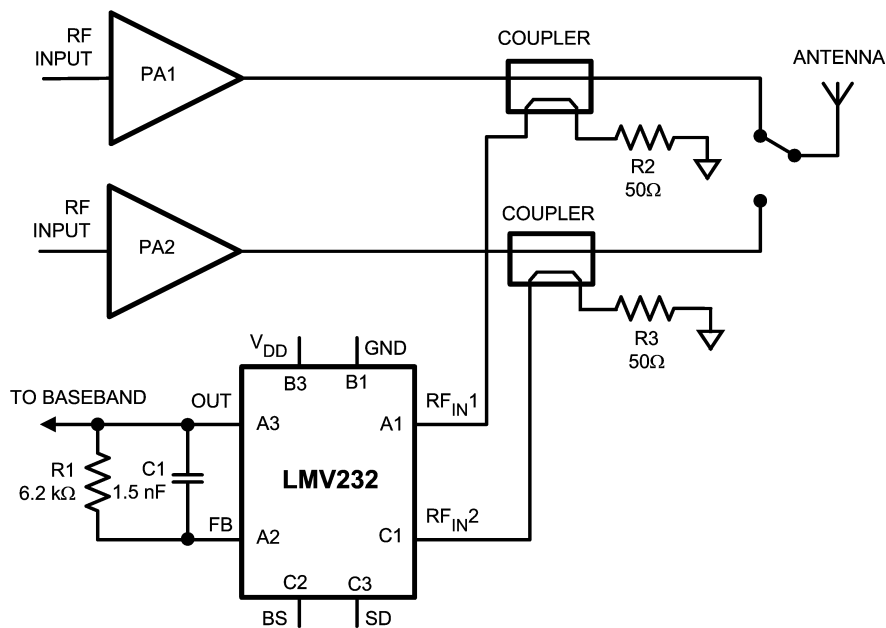

20127801

Absolute Maximum Ratings (Note 1)

If Military/Aerospace specified devices are required, please contact the National Semiconductor Sales Office/Distributors for availability and specifications.

Supply Voltage	
$V_{DD} - GND$	3.6V Max
ESD Tolerance (Note 2)	
Human Body Model	2000V
Machine Model	200V
Storage Temperature Range	-65°C to 150°C

Junction Temperature (Note 3)	150°C Max
Mounting Temperature	
Infrared or Convection (20 sec)	235°C

Operating Ratings (Note 1)

Supply Voltage	2.5V to 3.3V
Operating Temperature Range	-40°C to +85°C
RF Frequency Range	50 MHz to 2 GHz

2.7 DC and AC Electrical Characteristics

Unless otherwise specified, all limits are guaranteed to $V_{DD} = 2.7V$; $T_J = 25^\circ C$. **Boldface** limits apply at temperature extremes. (Note 4)

Symbol	Parameter	Condition	Min	Typ	Max	Units
I_{DD}	Supply Current	Active Mode: SD = LOW, No RF Input Power Present		9.8	11 13	mA
		Shutdown: SD = 1.8V, No RF Input Power Present		0.09	5 30	μA
V_{LOW}	BS and SD Logic Low Level (Note 6)				0.8	V
V_{HIGH}	BS and SD Logic High Level (Note 6)		1.8			V
I_{BS}, I_{SD}	Current into BS and SD pins				5	μA
V_{OUT}	Output Voltage Swing	From Positive Rail, Sourcing, FB = 0V, $I_{OUT} = 1$ mA		20	80 90	mV
		From Negative Rail, Sinking, FB = 2.7V, $I_{OUT} = -1$ mA		20	60 70	mV
I_{OUT}	Output Short Circuit	Sourcing, FB = 0V, $V_{OUT} = 2.6V$	3.7 2.7	5.1		mA
		Sinking, FB = 2.7V, $V_{OUT} = 0.1V$	3.7 2.7	5.5		
V_{OUT}	Output Voltage (Pedestal)	No RF Input Power	235 230	254	275 280	mV
V_{PED}	Pedestal Variation Over Temperature (Note 10)			5.4		mV
I_{OS}	Offset Current Variation Over Temperature (Note 10)			1.17		μA
t_{ON}	Turn-on-Time (Note 9)	No RF Input Power Present, Output Loaded with 10 pF		2.0	6.0	μs
t_R	Rise Time (Note 7)	Step from No Power to 0 dBm Applied, Output Loaded with 10 pF		4.5		μs
e_n	Output Referred Voltage Noise	RF Input = 1800 MHz, -10 dBm, Measured at 10 kHz		400		nV/\sqrt{Hz}
GBW	Gain Bandwidth Product			3.7		MHz
SR	Slew Rate		1.8 1.0	3.0		V/ μs
R_{IN}	DC Resistance	(Note 7)		50.8		Ω
P_{IN}	RF Input Power Range	RF Input Frequency = 900 MHz		-11 +13		dBm
				-24 0		dBV

2.7 DC and AC Electrical Characteristics (Continued)

Unless otherwise specified, all limits are guaranteed to $V_{DD} = 2.7V$; $T_J = 25^\circ C$. **Boldface** limits apply at temperature extremes. (Note 4)

Symbol	Parameter	Condition	Min	Typ	Max	Units
K_{DET}	Detection Slope	900 MHz		21		$\mu A/mW$
		1800 MHz		10		
		1900 MHz		10		
		2000 MHz		10		
f_{LOW}	LF Input Corner Frequency	Lower -3 dB Point of Detection Slope		60		MHz
f_{HIGH}	HF Input Corner Frequency	Upper -3 dB Point of Detection Slope		1.0		GHz
A_{ISO}	Channel Isolation	900 MHz		58		dB
		1800 MHz		62		
		1900 MHz		58		
		2000 MHz		55		

Note 1: Absolute Maximum Ratings indicate limits beyond which damage to the device may occur. Operating Ratings indicate conditions for which the device is intended to be functional, but specific performance is not guaranteed. For guaranteed specifications and the test conditions, see the Electrical Characteristics.

Note 2: Human body model: $1.5\text{ k}\Omega$ in series with 100 pF . Machine model, 0Ω in series with 100 pF .

Note 3: The maximum power dissipation is a function of $T_{J(MAX)}$, θ_{JA} and T_A . The maximum allowable power dissipation at any ambient temperature is $P_D = (T_{J(MAX)} - T_A)/\theta_{JA}$. All numbers apply for packages soldered directly into a PC board.

Note 4: Electrical Table values apply only for factory testing conditions at the temperature indicated. Factory testing conditions result in very limited self-heating of the device such that $T_J = T_A$. No guarantee of parametric performance is indicated in the electrical tables under conditions of internal self-heating where $T_J > T_A$.

Note 5: Power in dBV = dBm + 13 when the impedance is 50Ω .

Note 6: All limits are guaranteed by design or statistical analysis.

Note 7: Typical values represent the most likely parametric norm.

Note 8: Device is set in active mode with a $10\text{ k}\Omega$ resistor from V_{DD} to RF_{IN}/E_N . RF signal is applied using a 50Ω RF signal generator AC coupled to the RF_{IN}/E_N pin using a 100 pF coupling capacitor.

Note 9: Turn-on time is measured by connecting a $10\text{ k}\Omega$ resistor to the RF_{IN}/E_N pin. Be aware that in the actual application on the front page, the RC-time constant of resistor R2 and capacitor C adds an additional delay.

Note 10: Typical numbers represent the 3-sigma value of 10k units. 3-sigma value of variation between $-40^\circ C / 25^\circ C$ and variation between $25^\circ C / 85^\circ C$.

Connection Diagram

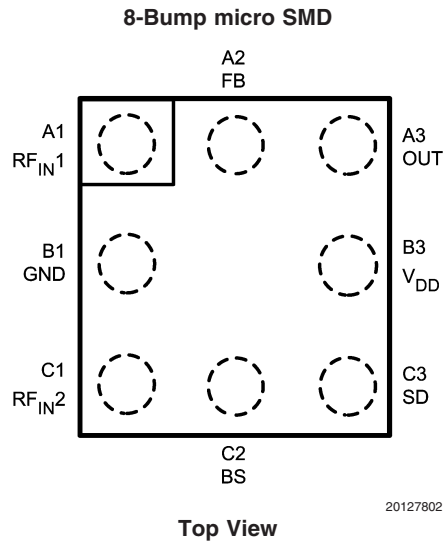

Pin Description

	Pin	Name	Description
Power Supply	B3	V_{DD}	Positive Supply Voltage
	B1	GND	Power Ground
Digital Inputs	C3	SD	Schmitt-triggered Shutdown. The device is active for SD = LOW. For SD = HIGH, it is brought into a low-power shutdown mode.
	C2	BS	Schmitt-triggered Band Select pin. When BS = HIGH, RF_{IN1} is selected, when BS = LOW, RF_{IN2} is selected.
Analog Inputs	A1	RF_{IN1}	RF Input connected to the coupler output with optional attenuation to measure the Power Amplifier (PA) / Antenna RF power levels. Both RF inputs of the device are internally terminated with a 50Ω resistance.
	C1	RF_{IN2}	
Feedback	A2	FB	Connected to inverting input of output amplifier. Enables user-configurable gain and bandwidth through external feedback network.
Output	A3	Out	Amplifier output

Ordering Information

Package	Part Number	Package Marking	Transport Media	NSC Drawing
8-Bump micro SMD	LMV232TL	A	250 Units Tape and Reel	TLA08AAA
	LMV232TLX	I 02	3k Units Tape and Reel	

Note: This product is only offered with lead free bumps.

Block Diagrams

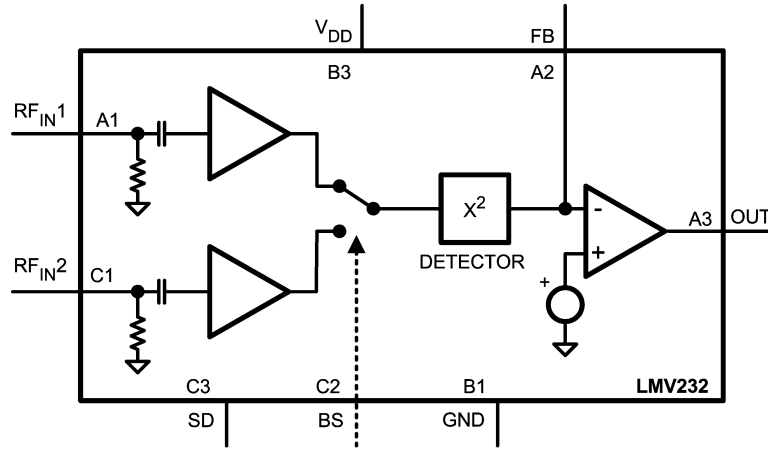

LMV232

20127864

Typical Performance Characteristics Unless otherwise specified, $V_{DD} = 2.7V$, $T_J = 25^\circ C$, $R1 = 6.2\ k\Omega$ and $C1 = 1.5\ nF$ (See typical application on the frontpage).

Supply Current vs. Supply Voltage

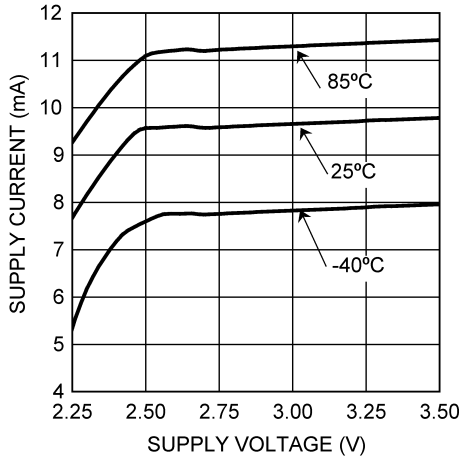

20127877

$V_{OUT} - V_{PEDESTAL}$ vs. RF Input Power

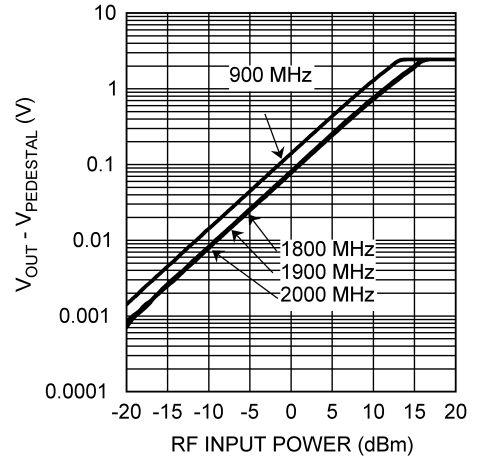

20127867

$V_{OUT} - V_{PEDESTAL}$ vs. RF Input Power @ 900 MHz

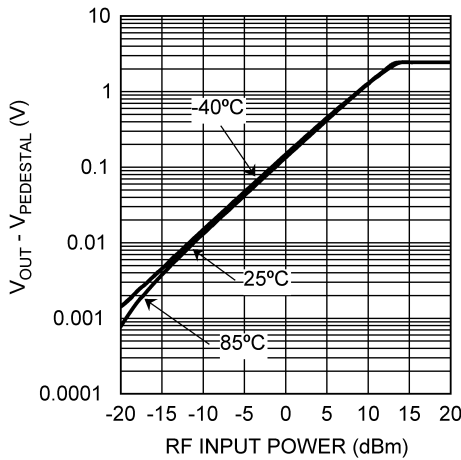

20127868

Input Referred Error vs. RF Input Power @ 900 MHz

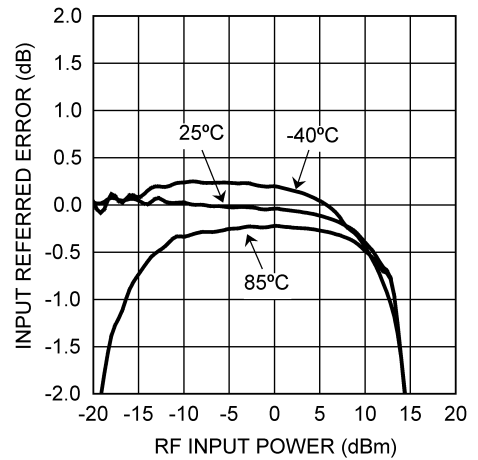

20127869

$V_{OUT} - V_{PEDESTAL}$ vs. RF Input Power @ 1800 MHz

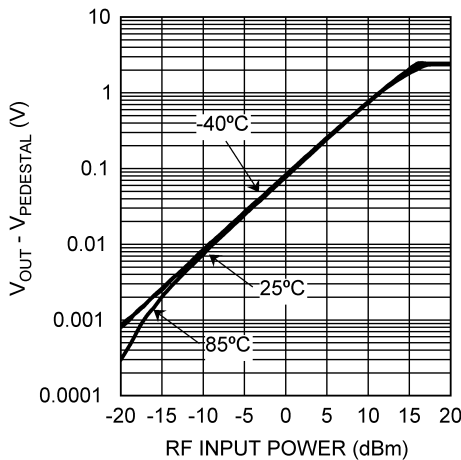

20127870

Input Referred Error vs. RF Input Power @ 1800 MHz

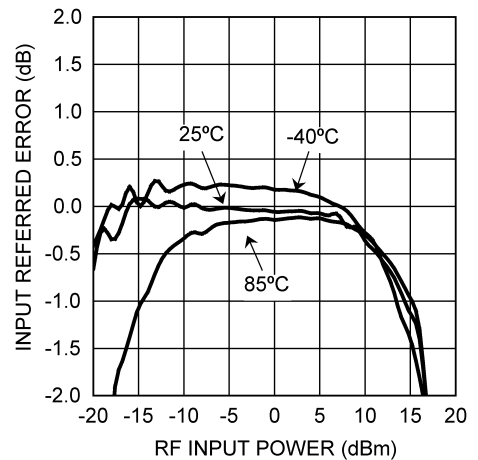

20127871

Typical Performance Characteristics Unless otherwise specified, $V_{DD} = 2.7V$, $T_J = 25^\circ C$, $R1 = 6.2\ k\Omega$ and $C1 = 1.5\ nF$ (See typical application on the frontpage). (Continued)

$V_{OUT} - V_{PEDESTAL}$ vs. RF Input Power @ 1900 MHz

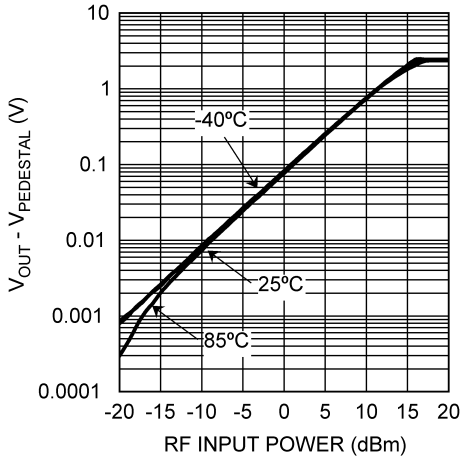

20127872

Input Referred Error vs. RF Input Power @ 1900 MHz

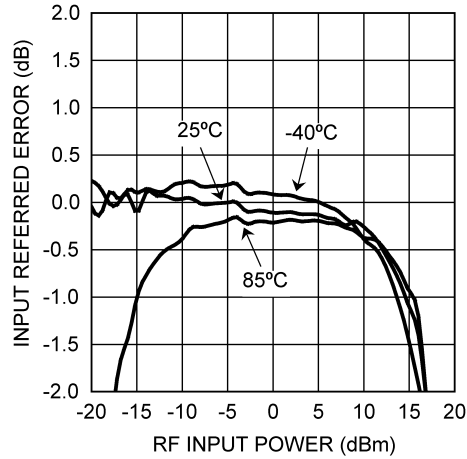

20127873

$V_{OUT} - V_{PEDESTAL}$ vs. RF Input Power @ 2000 MHz

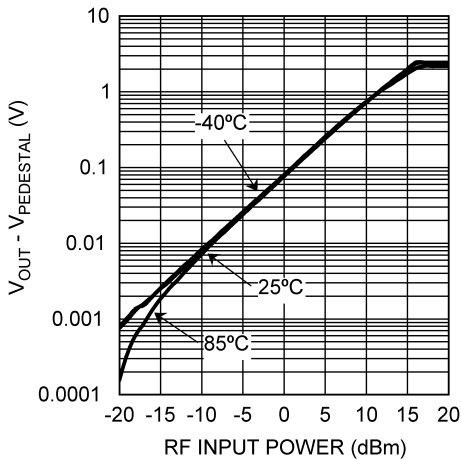

20127874

Input Referred Error vs. RF Input Power @ 2000 MHz

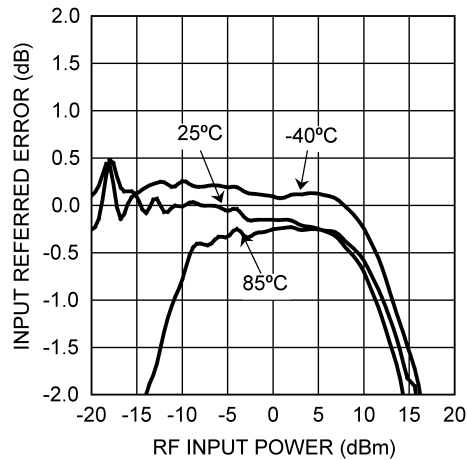

20127875

$V_{OUT} - V_{PEDESTAL}$ vs. RF Input Power @ 1900 MHz

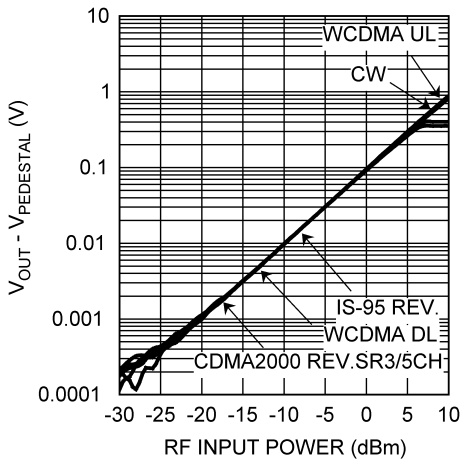

20127882

Input Referred Error vs. RF Input Power @ 1900 MHz

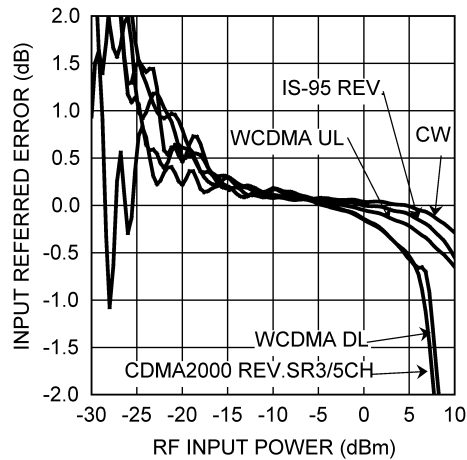

20127883

Typical Performance Characteristics Unless otherwise specified, $V_{DD} = 2.7V$, $T_J = 25^\circ C$, $R1 = 6.2\ k\Omega$ and $C1 = 1.5\ nF$ (See typical application on the frontpage). (Continued)

RF Input Impedance vs. Frequency @ Resistance and Reactance

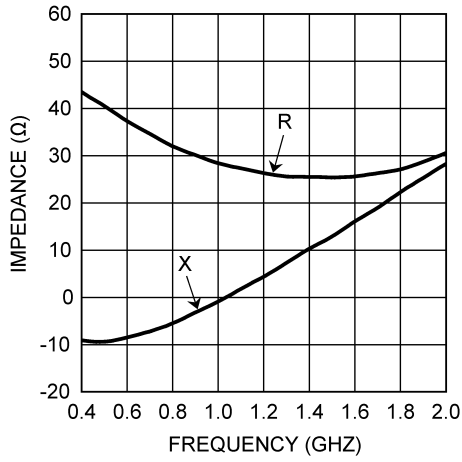

20127876

Gain and Phase vs. Frequency

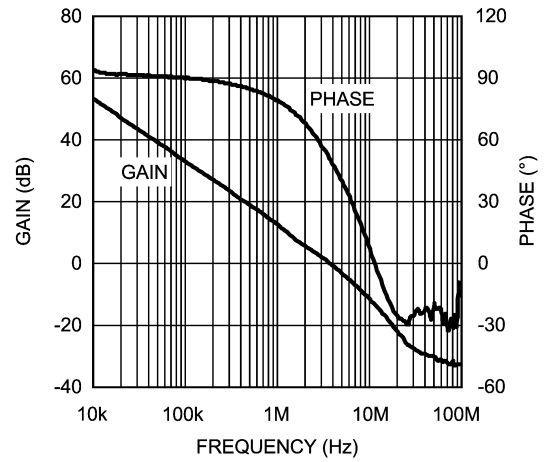

20127804

Sourcing Current vs. Output Voltage

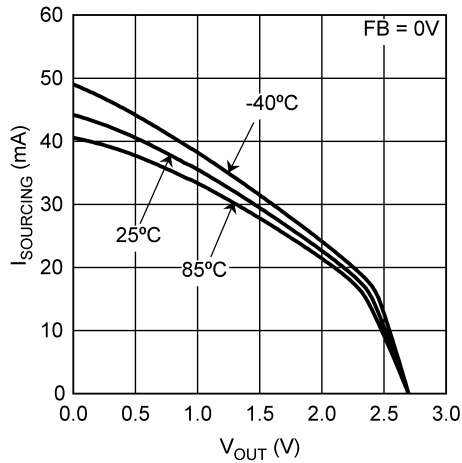

20127878

Sinking Current vs. Output Voltage

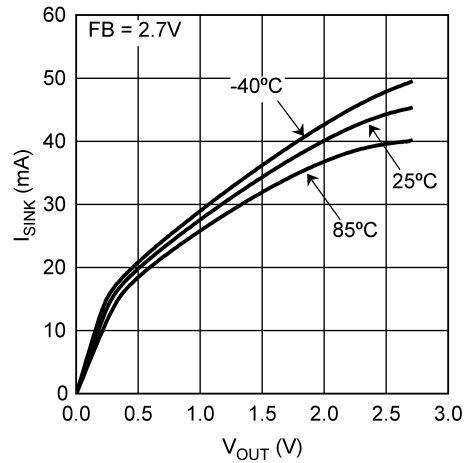

20127879

Output Voltage vs. Sourcing Current

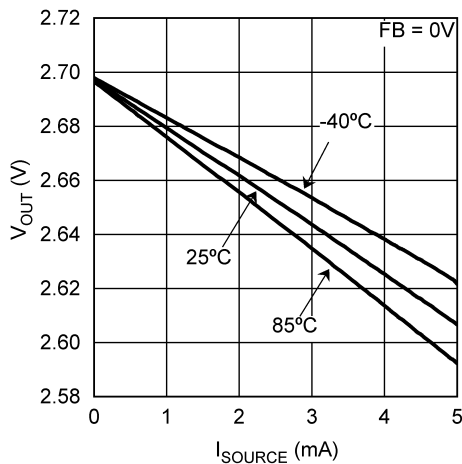

20127880

Output Voltage vs. Sinking Current

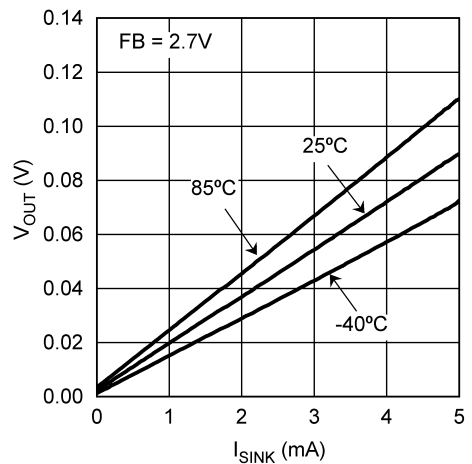

20127881

Application Notes

The LMV232 mean square power detector is particularly suited for accurate power measurement of RF modulated signals that exhibit large peak to average ratios, i.e. large variations of the signal envelope. Such noise-like signals are encountered e.g. in CDMA and Wide-band CDMA cell-phones. Many power detection circuits, particularly those devised for constant-envelope modulated signals as in GSM, are based on peak detection and provide accurate power measurements for constant envelope or low-crest factor (ratio of peak to RMS) signals only. Such detectors are therefore not particularly suited for CDMA and WCDMA applications.

TYPICAL APPLICATION

The LMV232 is especially suited for CDMA and WCDMA applications with 2 Power Amplifiers (PA's). A typical setup is given in *Figure 1*. The output power of one PA is measured at a time, depending on the bandselect pin (BS). If the BS = High RF_{IN1} is used for measurements, if BS = Low RF_{IN2} is used. The measured output voltage of the LMV232 is read by the ADC of the baseband chip and the gain of the PA gain is adjusted if necessary. With an input impedance of 50Ω, the LMV232 can be directly connected to a 20 dB directional coupler without the need for an additional external attenuator. The setup can be adjusted to various PA output ranges by selection of a directional coupler or insertion of an additional (resistive) attenuator between the coupler outputs and the LMV232 RF inputs.

The LMV232 conversion gain and bandwidth are configured by a resistor and a capacitor. Resistor R1 sets the conversion gain from RF_{IN} to the output voltage. A higher resistor value will result in a higher conversion gain. The maximum dynamic range is achieved when the resistor value is as high as possible, i.e. the output signal just doesn't clip and the

voltage stays within the baseband ADC input range. The filter bandwidth is adjusted by capacitor C1. The capacitor value should be chosen such that the response time of the device is fast enough and modulation on the RF input signal is not visible at the output (ripple suppression). The -3 dB filter bandwidth of the output filter is determined by the time constant $R1 \cdot C1$. Generally a capacitor value of 1.5 nF is a good choice.

PEAK TO AVERAGE RATIO SENSITIVITY

The LMV232 power detector provides an accurate power measurement for arbitrary input signals, low and high peak-to-average ratios and crest factors. This is because its operation is not based on peak detection, but on direct determination of the mean square value. This is the most accurate power measurement, since it exactly implements the definition of power. A mean-square detector measures V_{RMS}^2 for all waveforms. Peak detection is less accurate because the relation between peak detection and mean square detection depends on the waveform. A peak detector measures $P = V_{PEAK}^2$ for all waveforms, while it should measure $P = V_{PEAK}^2/2$ (for $R = 1\Omega$) for a sine wave and $P = V_{PEAK}^2/3$ for a triangle wave for instance. For a CDMA signal, the measurement error can be in the order of 5 to 6 dB. For many wave forms, specially those with high peak-to-average ratios, peak detection is not accurate enough and therefore a mean square detector is recommended.

MEAN SQUARE CONFORMANCE ERROR

The LMV232 is a mean square detector and therefore should have an output voltage (in Volts) that linearly relates to the RF input power (in mW). The input referred error, with respect to an ideal linear mean square detector, is determined as a measure for the accuracy of the detector.

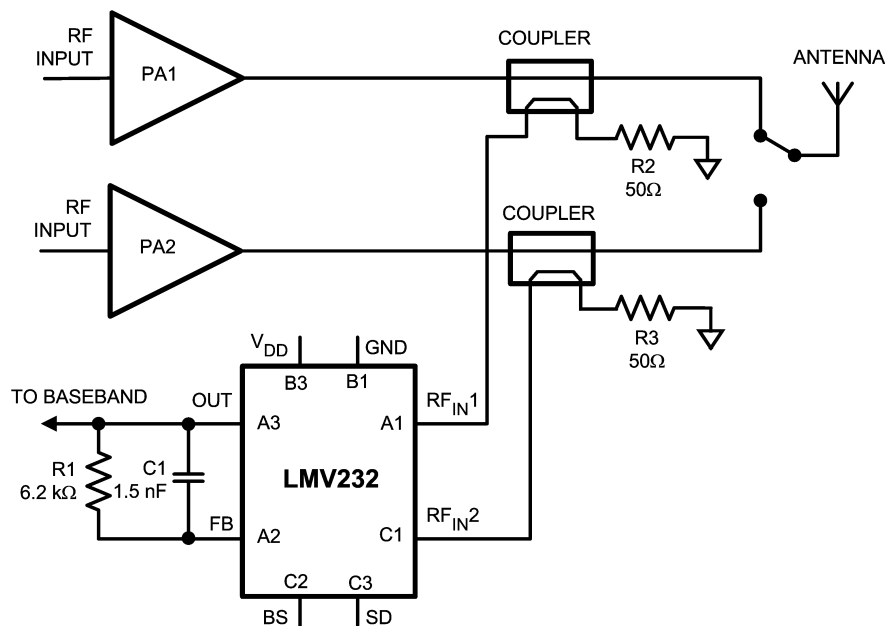

20127801

FIGURE 1. Typical Application

Application Notes (Continued)

The detection curves of *Figure 2* show the detector response to RF input power. To show the complete dynamic range on a logarithmic scale, the pedestal voltage ($V_{PEDESTAL}$) is subtracted from the output. The pedestal voltage is defined as the output voltage in the absence of an RF input signal (at 25°C). The best-fit ideal mean square response is represented by the fitted curve in *Figure 2*. The input referred error of the detection curves with respect to this best-fit mean square response is determined as follows:

- Determine the best-fit mean square response.
- Determine the output referred error between the actual detector response and the ideal mean square response.
- Translate the output referred error to an input referred error.

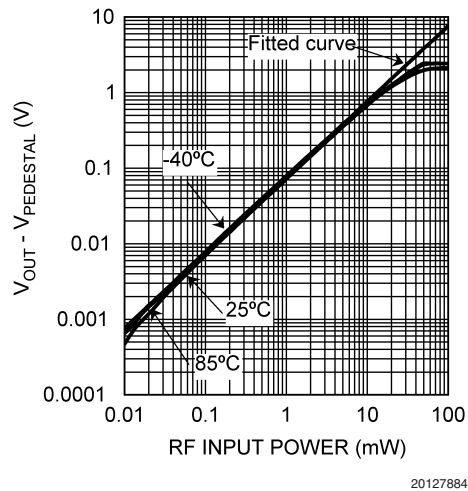

FIGURE 2. Detection Curve

The best-fit linear curve is obtained from the detector response by means of linear regression. The output referred error is calculated with the formula:

$$\text{Error}_{\text{dBV}} = 20 \cdot \log \left[\frac{V_{\text{OUT}} - V_{\text{PEDESTAL}}}{K_{\text{DET}} \cdot P_{\text{IN}}} \right]$$

Where,

Conversion gain of the ideal fitted curve K_{DET} is in V/mW and the RF input power P_{IN} in mW.

To translate this output referred error (in dB) to an input referred error, it has to be divided by a factor of 2. This is due to the mean square characteristic of the device. The response of a mean square detector changes by 2 dB for every dB change of the input power. *Figure 3* depicts the resulting curve.

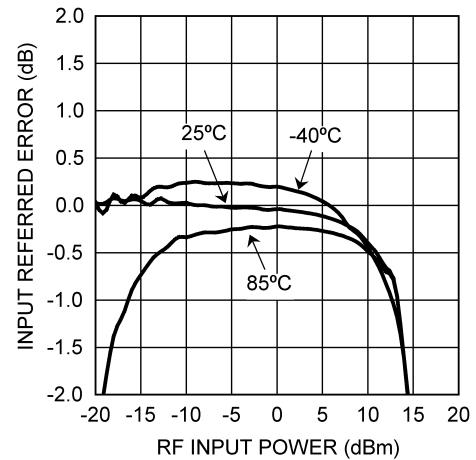

FIGURE 3. Input referred Error vs. RF Input Power

Analyzing *Figure 3* shows that three sections can be distinguished:

- At higher power levels the error increases.
- A middle section where the error is constant and relatively small.
- At lower power levels the error increases again.

These three sections are leading back to three error mechanisms. At higher power levels the detectors output starts to saturate because the output voltage approaches the maximum signal swing that the detector can handle. The maximum output voltage of the device thus limits the upper end of the detection range. Also the maximum allowed ADC voltage of the baseband chip can limit the detection range at higher power levels. By adjusting the feedback resistor R_{FB} of *Figure 1* the upper end of the range can be shifted. This is valid until the detector cell inside the LMV232 is the limiting factor.

The middle section of the error curve shows a small error variation. This is the section where the detector is used and is called the detection range of the detector. This range is limited on both sides by a maximum allowed error.

For low input power levels, the variation of output voltage is very small. Therefore the measurement resolution ADC is important in order to measure those small variations. Offsets and temperature variation impact the accuracy at low power levels as well.

DETECTION ERROR OVER TEMPERATURE

Like any power detector device, the output signal of the LMV232 mean square power detector shows some residual variation over temperature that limits its dynamic range. The variation determines the accuracy and range of input power levels for which the detector produces an accurate output signal.

The error over temperature is mainly caused by the variation of the pedestal voltage. Besides this, a minimal error contribution leads back to the conversion gain variation of the detector. This conversion gain error is visible in the mid-power range, where the temperature error curves of *Figure 3* run parallel to each other. Since the conversion gain variation is acceptable, the focus will be on the pedestal voltage variation over temperature.

Application Notes (Continued)

The pedestal voltage at 25°C is subtracted from the output voltage of each curve. Variations of the pedestal voltage over temperature are thus included in the error.

The pedestal voltage variation itself consists of 2 error sources. One is the variation of the reference voltage V_{REF} . The other is an offset current I_{OS} that is generated inside the detector. This depicted in *Figure 4*. Depending on the measurement strategy one or both error sources can be eliminated.

The error sources of the pedestal voltage can be shown in a formula for V_{OUT} :

$$V_{OUT} = V_{REF} + (I_{OS} + I_{DET}) * R_{FB}$$

Where I_{DET} represents the intended detector output signal. In the absence of RF input power I_{DET} equals zero. The formula for the pedestal voltage can therefore be written as:

$$V_{PEDESTAL} = V_{REF} + I_{OS} * R_{FB}$$

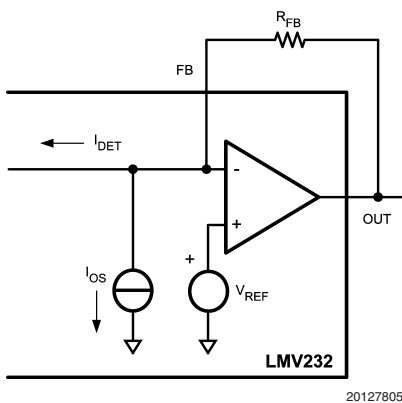

FIGURE 4. Pedestal Voltage

For low input power levels, the pedestal variation $V_{PEDESTAL}$ is the dominant cause of error. Besides temperature variation of the pedestal voltage, which limits the lower end of the range, the pedestal voltage can also vary from part-to-part. By applying a suitable measurement strategy, the pedestal voltage error contribution can be significantly reduced or eliminated completely.

POWER MEASUREMENT STRATEGIES

This section describes the measurement strategies to reduce or eliminate the pedestal voltage variation. Which strategy is chosen depends on the possibilities for a factory trim and implementation of calibration procedures.

Since the pedestal voltage is the reference level for the LMV232, it needs to be calibrated/measured at least once to eliminate part-to-part spread. This is required to determine the exact detector output signal. Because of process tolerances, the absolute part-to-part variation of the output voltage in the absence of RF input power will be in the order of 5 - 10%. All measurement strategies discussed eliminate this part-to-part spread.

Strategy 1: Elimination of Part-to-Part Spread at Room Temperature Only

In this strategy, the pedestal voltage is determined once during manufacturing and stored into the memory of the phone. At each power measurement this stored pedestal

level is digitally subtracted from the measured output signal of the LMV232 during normal operation. The procedure is thus:

- Measure the detector output in the absence of RF power during manufacturing.
- Store the output voltage value in the cell phone memory (after it is analog-to-digital converted).
- Subtract the stored value from each detector output reading.

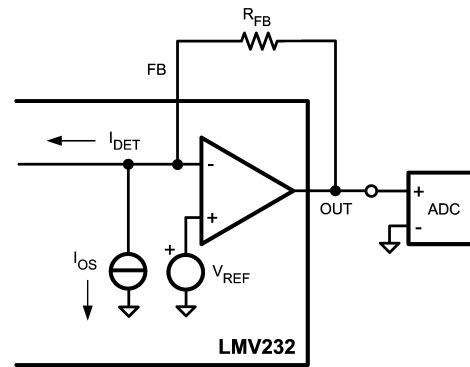

FIGURE 5. Strategy 1: Room Temperature Calibration

The advantage of this strategy is that calibration is required only once during manufacturing and not during normal operation. The disadvantage is the fact that this method neither compensates for the residual temperature drift of the reference voltage V_{REF} nor for offset current variations. Only part-to-part variations at room temperature are eliminated by this strategy. Especially the residual temperature drift negatively affects the measurement accuracy.

Strategy 2: Elimination of Temperature Spread in V_{REF}

If software changes need to be reduced to a minimum and the baseband chip has a differential ADC, strategy 2 can be used to eliminate temperature variations of the reference voltage V_{REF} . One pin of the ADC is connected to FB and one is connected to OUT (*Figure 6*).

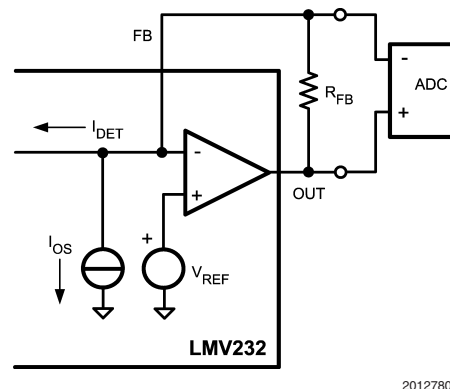

FIGURE 6. Strategy 2: Differential Measurement

The power measurement is independent of the reference voltage V_{REF} , since the ADC reading is:

$$V_{OUT} - V_{FB} = (I_{OS} + I_{DET}) * R_{FB}$$

Application Notes (Continued)

The reading of the ADC obviously doesn't contain the reference voltage source V_{REF} anymore, but the contribution of the offset current remains present. This measurement is performed during normal operation. Therefore, it eliminates voltage reference variations over temperatures, as opposed to strategy 1. Also offset variations in the op amp are eliminated in this strategy.

Strategy 3: Complete Elimination of Temperature Spread in Pedestal Voltage

The most accurate measurement is strategy 3, which eliminates the temperature variation of both the reference voltage V_{REF} and the offset current I_{OS} . In this strategy, the pedestal voltage is measured regularly during operation of the phone, and stored in the phone memory. For each power measurement, the stored value is digitally subtracted from the (analog-to-digital converted) detector output signal. Since it measures the pedestal voltage itself for calibration it compensates both for the reference voltage V_{REF} as well as for the offset current variation I_{OS} . The frequency of the 'calibration measurement' can be significantly lower than those of power measurements, depending on how fast the temperature of the device changes.

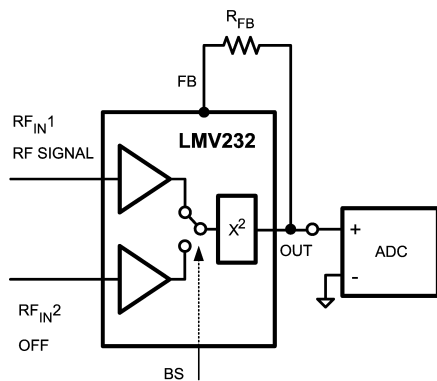

20127808

FIGURE 7. Strategy 3: Calibration during normal operation

The calibration measurement procedure can be explained with the aid of *Figure 1*, which depicts a typical power measurement setup using the LMV232. In normal operation, the two PA's in the setup will never be active at the same time. One PA will produce the required transmit power, while the other one is off, (disabled) and produces no power. The pedestal voltage should be measured in the absence of RF power. This can be achieved by switching the Band Select (BS) pin such that the LMV232 input is selected where the disabled PA is connected to. The pedestal voltage at no input power can be read at the output pin.

Using the Band Select (BS) control pin of the LMV232:

- Select the RF input that is connected to the disabled PA, by the BS pin.
- Measure the detector output.
- Store the result in the phone memory.
- Subtract the stored value from each detector power reading, until a new update is performed.

Important advantages of this approach are that no factory trim is required and the temperature drift of the pedestal can be cancelled almost completely as well as the part-to-part spread. The remaining error is determined by the resolution of the ADC. A slight disadvantage is that on average more than one detector reading is required per power measurement. This overhead though can be made almost negligible in normal circumstances.

Physical Dimensions inches (millimeters) unless otherwise noted

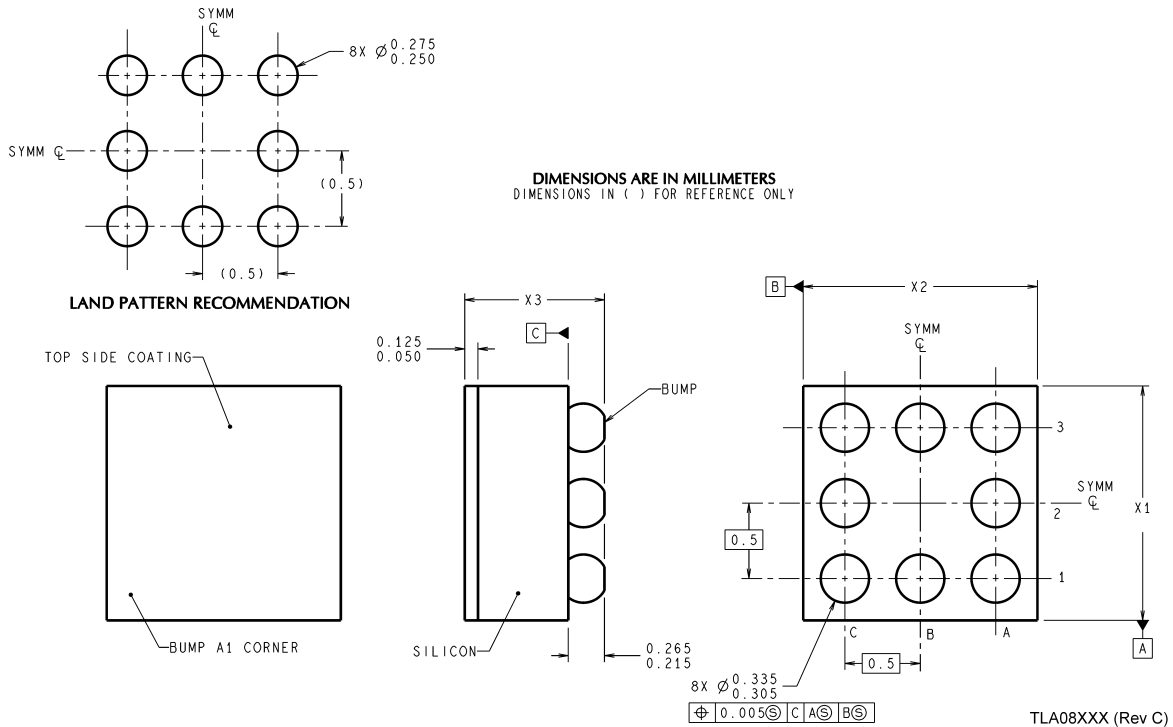

NOTES: UNLESS OTHERWISE SPECIFIED

1. EPOXY COATING
 2. FOR SOLDER BUMP COMPOSITION, SEE "SOLDER INFORMATION" IN THE PACKAGING SECTION OF THE NATIONAL SEMICONDUCTOR WEB (www.national.com).
 3. RECOMMEND NON-SOLDER MASK DEFINED LANDING PAD.
 4. PIN A1 IS ESTABLISHED BY LOWER LEFT CORNER WITH RESPECT TO TEXT ORIENTATION.
 5. XXX IN DRAWING NUMBER REPRESENTS PACKAGE SIZE VARIATION WHERE X1 IS PACKAGE WIDTH, X2 IS PACKAGE LENGTH AND X3 IS PACKAGE HEIGHT.
- REFERENCE JEDEC REGISTRATION MO-211, VARIATION DD.

8-Bump micro SMD
NS Package Number TLA08AAA
X1 = 1.514 ±0.030 mm X2 = 1.514 ±0.030 mm X3 = 0.600 ±0.075 mm

National does not assume any responsibility for use of any circuitry described, no circuit patent licenses are implied and National reserves the right at any time without notice to change said circuitry and specifications.

For the most current product information visit us at www.national.com.

LIFE SUPPORT POLICY

NATIONAL'S PRODUCTS ARE NOT AUTHORIZED FOR USE AS CRITICAL COMPONENTS IN LIFE SUPPORT DEVICES OR SYSTEMS WITHOUT THE EXPRESS WRITTEN APPROVAL OF THE PRESIDENT AND GENERAL COUNSEL OF NATIONAL SEMICONDUCTOR CORPORATION. As used herein:

1. Life support devices or systems are devices or systems which, (a) are intended for surgical implant into the body, or (b) support or sustain life, and whose failure to perform when properly used in accordance with instructions for use provided in the labeling, can be reasonably expected to result in a significant injury to the user.
2. A critical component is any component of a life support device or system whose failure to perform can be reasonably expected to cause the failure of the life support device or system, or to affect its safety or effectiveness.

BANNED SUBSTANCE COMPLIANCE

National Semiconductor manufactures products and uses packing materials that meet the provisions of the Customer Products Stewardship Specification (CSP-9-111C2) and the Banned Substances and Materials of Interest Specification (CSP-9-111S2) and contain no "Banned Substances" as defined in CSP-9-111S2.



National Semiconductor
Americas Customer Support Center
 Email: new.feedback@nsc.com
 Tel: 1-800-272-9959

National Semiconductor
Europe Customer Support Center
 Fax: +49 (0) 180-530 85 86
 Email: europe.support@nsc.com
 Deutsch Tel: +49 (0) 69 9508 6208
 English Tel: +44 (0) 870 24 0 2171
 Français Tel: +33 (0) 1 41 91 8790

National Semiconductor
Asia Pacific Customer Support Center
 Email: ap.support@nsc.com

National Semiconductor
Japan Customer Support Center
 Fax: 81-3-5639-7507
 Email: jpn.feedback@nsc.com
 Tel: 81-3-5639-7560